

BubbleFlush

WATER STOP

Water Stop - User Manual

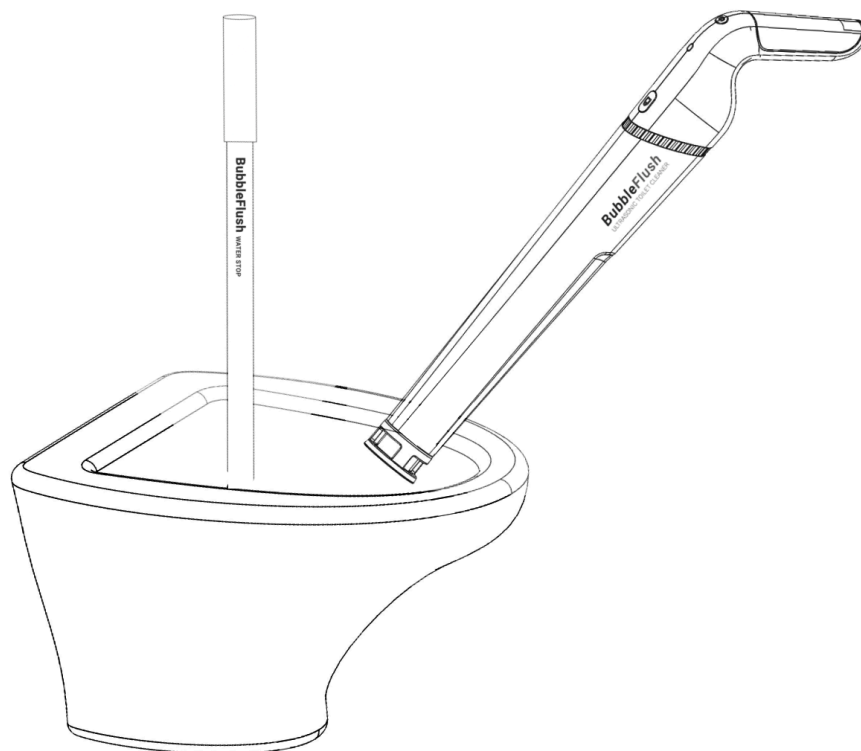

12 Juni 2023 - V1.9 Translate version

BubbleFlush B.V.

Industrieweg 4D, Zoetermeer, Nederland
+31 (0)79 343 6313
www.bubbleflush.com
info@bubbleflush.com

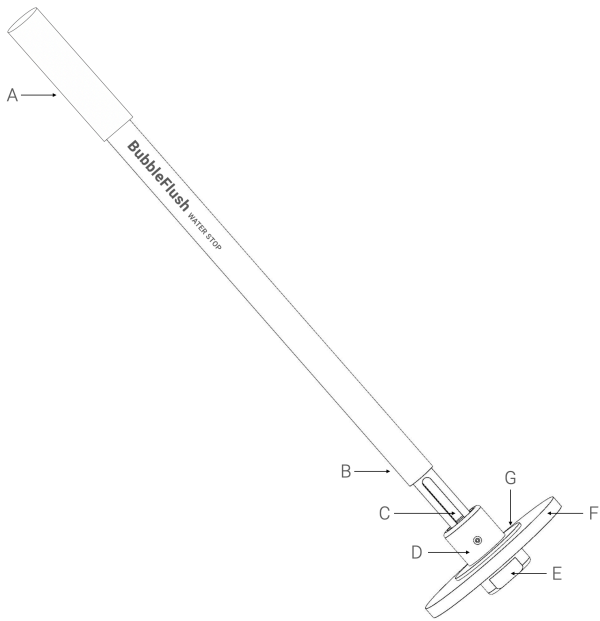

1.



Scan for more information

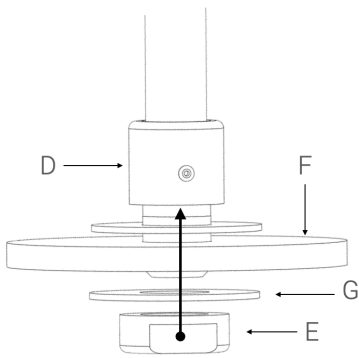

2.

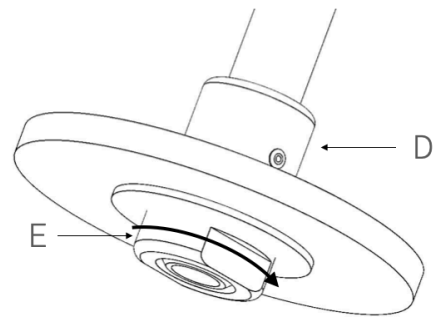

3.

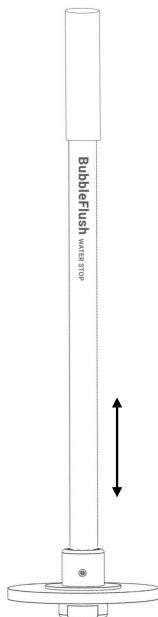

4.

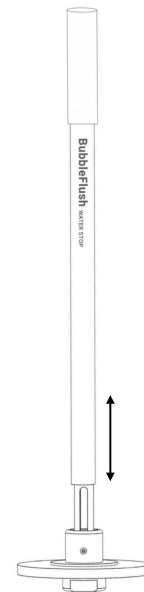

5.

English

(translation of the original user guide)

Declaration of general data (Fig. 1)

A Handle	E Foam disc
B Sliding outer tube	F Plastic nut
C Water inlet	G Lock-up rings
D Adapter	

TECHNICAL DATA

Dimensions (cm)	17 x 53
Weight (kg)	0,35
Operating conditions	10 - 40 °C

Intended use of the product (fig. 1)

The product is intended as an accessory to the "BubbleFlush Ultrasonic Toilet Cleaner" to temporarily raise the water level in the toilet for cleaning the upper part of the toilet using the existing (clean) toilet water without using chemicals. The intended life of the product is 3 to 5 years depending on the frequency of use. The foam disc will need to be replaced regularly. Any modification of the product may affect safety and warranty.

WARNING Read all safety warnings and all instructions.

Failure to follow the warnings and instructions may result in personal injury, damage to the product or other property.

Keep all warnings and all instructions for future reference.

SAFETY WARNINGS

- Use the product only with the available (clean) toilet water.
- Use of chemicals does not enhance the product's performance and may possibly cause unexpected reactions in the toilet water.
- Be careful not to drop the product or bump into anything.
- The product must not be used by persons (including children) with reduced physical, sensory or mental capabilities or lack of experience and knowledge, unless they are supervised or have received instructions.
- Supervision must be provided to ensure that children do not play with the product.
- Hold the product firmly during use.
- Do not disassemble the product.

KEEP THESE INSTRUCTIONS

Warning

DO NOT be misled by a false sense of comfort and familiarity with the product (after frequent use) and always strictly observe all safety instructions of the respective product.

WRONG USE or failure to follow the safety instructions in these instructions may result in serious personal injury.

DESCRIPTION OF FUNCTIONS

Inserting the foam disc (fig. 2 and 3)

- Hold the adapter [D] and unscrew/click the plastic nut [E] from the bottom of the product.
- Place the new foam disc [F] between the two lock-up rings [G].
- Hold the adapter above the foam disc and turn/click the plastic nut back on the bottom of the product.
- Before use, check that the foam disc is securely attached.

Replacing the foam disc (fig. 2 and 3)

- Hold the adapter [D] above the foam disc [F] and unscrew/click the plastic nut [E] at the bottom of the product.

- Remove the old foam disc.
- Place the new foam disc between the two lock-up rings [G].
- Hold the adapter above the foam disc and turn/click the plastic nut back on the bottom of the product.
- Before use, check that the foam disc is securely attached.

Using the product (fig. 4 and 5)

- Before use, check that the foam disc is securely attached.
- Insert the product's foam disc into the toilet's siphon and push the foam disc below the water line.
- Flush the toilet to fill the toilet with water.
- You can lower the water level by gently pulling up the handle of the product. The water inlet will become visible and the water level will slowly decrease.
- Clean the toilet with the "BubbleFlush Ultrasonic Toilet Cleaner".
- After cleaning, carefully remove the product from the toilet by pulling up the handle of the product.
- If required, rinse the product under a tap after use.

Caution

- Before use, always check that the plastic nut holding the foam disc is securely locked.
- For stubborn soiling, you may need to repeat the cleaning process. Old or stubborn soiling may not disappear in one cleaning.
- With significant soiling of the toilet, additional soiling may loosen when flushing after cleaning and be visible in the siphon.

MAINTENANCE

Periodic cleaning and maintenance product

- Wipe the product with a damp cloth.
- The foam disc can be cleaned wet.
- The foam disc should be replaced periodically.